

EEG Cortical Signal Measurement and Processing System  
for Automatic Artifact Removal, Evaluation, and Remote  
Monitoring of Cochlear Implants

Haotian Xu

## Personal

Imagine being plunged perpetually into a silence where the ubiquity of sound is irrelevant. That is the world which many students in my high school experience.

My inspiration for this project really came from the students in my high school's Deaf and Hard of Hearing (DHH) program. My school has a department which offers a high school education to DHH students across Orange County. The students in this program take many of the same classes as the other students, using an interpreter to understand the lectures. I befriended several DHH students, but one in particular stood out to me: a boy in Cross Country who was deaf but used a device called the cochlear implant to hear. During the team's annual trip to Yosemite each summer, he picked a song on a friend's MP3 player and played it. He then told the group that the song he chose was his favorite song. This moment inspired me, as it showed me that even deaf individuals could find enjoyment from music. As a pianist for 12 years, I felt an urge to help him and other DHH students fully experience the wonders of music.

The following summer I decided to take action. After doing a little background research on the device that enabled my friend to hear, I discovered that the Hearing and Speech Lab in the University of California, Irvine was currently researching how to improve the cochlear implant. I contacted the professor, and he invited me to sit in during a lab meeting. After showing up and listening to several veterans in the field discuss topics I couldn't begin to comprehend, I mustered up the courage to ask to participate in research on cochlear implants in his lab. He agreed, and allowed me to work under a post-doc.

So let me give a bit of background information on the cochlear implant. The cochlear implant bypasses the outer, middle, and inner ear by sending electrical stimulation directly up the auditory nerve to the temporal lobes of the brain. This electrical stimulation mimics the natural electrical signals

produced by the hair cells in the cochlea, and the implant users are able to interpret this as sound. Because it completely bypasses the ear, this device enables otherwise deaf or critically hard of hearing individuals to hear.

After I got a spot in the lab, the next step was to decide the topic on which I would conduct research. Both my parents are electrical engineers, so naturally I had a strong foundation and interest in the engineering side of cochlear implants. And my mentor, the post-doc, told me that since he had a very busy schedule, he would only be willing to devote time to mentor me if my work pertained directly to his own research. We discussed possible topics and eventually decided that I should work on specializing the electroencephalogram (EEG) system used in cochlear implant fitting for cochlear implant applications.

Now let me give a bit of background information on the EEG system and cochlear implant fitting. Each cochlear implant has several electrodes used to stimulate different parts of the cochlea. Due to the small size of the cochlea (it's the size of a pea), even small deviations of a couple millimeters in the placement of the implant during surgery can have dramatic effects on the hearing of the patient. This makes it necessary for the implant to be fine-tuned by an audiologist for each individual user. Furthermore, because the cochlea of the patient continues to develop during the use of the implant, patients must return for a regular fitting every few months.

During fitting, most audiologists would individually adjust each electrode of the implant by asking the patient whether he or she felt that the loudness was comfortable. However, this is a highly subjective method, as the definition of "comfortable" will be different for each individual, and what one person feels is comfortable one day may not be true the next day. However, a larger problem emerges when cochlear implants are used on infants born with hearing impairment: it is impossible to ask a child whether a sound is loud enough, and guessing is dangerous because too high levels of stimulation may

damage the child's auditory nerve and too low levels will result in the child's auditory system failing to develop.

This is where the EEG comes in: the EEG system is an electronic system which uses electrodes attached to the person's head to scan the cortical evoked potential (CEP), the total electrical potential of neural activity in a person's brain. Every sound a person hears incites a neural response whose magnitude is directly proportional to the volume of the sound. Thus, by measuring the CEP signal, the audiologist is able to objectively assess how well the cochlear implant is working.

Unfortunately, the electrical signal generated by the cochlear implant to stimulate the auditory nerve is thousands of times stronger than the body's neural response to that stimulus, masking the signals the audiologist needs to record. But fortunately, this electrical artifact is a square-wave function, and thus has a very high frequency on its way up and down, usually many kiloHertz to the body's signals of between 2 and 35 Hertz. Thus, by filtering out the high-frequency noise, the EEG is able to collect and record data of the body's CEP signals.

So far, there are no commercially available EEG systems specialized for use in cochlear implant applications. Current systems are usually high-end, general-application EEG systems equipped with a band-pass filter. The problem with these systems is that they're quite large and (more importantly) very expensive. The system used in the lab, for example, was the NeuroScan SynAmps2, which costs \$50,000. The cheaper model assembled by my mentor from the Stanford Research Systems SR560 Low-Noise Voltage Preamplifier and the National Instruments USB-6221 Data Acquisition device cost \$2000 and \$3000, respectively, for a total of \$5000. My job, the topic of my research, would be to design and construct an EEG system specialized for cochlear implant applications by making it smaller, simpler, and cheaper while still being able to handle the large electrical artifact from the implant.

Almost everything involved in developing the EEG system was novel to me. First off, the software required to control the EEG system would be written in Matlab, a complex programming

language that performs a wide range of math- and science-related functions. Although I had some prior programming experience, I had only worked on simple graphics design in the programming language Processing. I had nothing as large as the project I was undertaking, nor any experience in any language of comparable complexity to Matlab. On the hardware side, the circuits necessary to construct an EEG system from scratch would require knowledge of electronics far beyond the materials covered in my high school Physics course. My parents had taught me some basic principles of electronics, but nothing in the caliber of constructing my own machine. To make up for my lack of experience in these aspects, I read materials from online sources and from the college library. Luckily, my strong background in math gave me the fundamentals necessary to learn the topic. By the end of my research, I had grasped both the basics of Matlab programming and of circuit design and construction.

# Research

## 1. Introduction

Hearing loss is a major public health concern in the United States. One in every six American adults have reported hearing problems, with half of people over 75 years old suffering from some form of hearing loss [1]. The U.S. Food and Drug Administration reported in 2010 that approximately 219,000 people with hearing impairments worldwide have had their ability to hear partially restored by a cochlear implant (CI), and this number is rapidly increasing. Many CI users are able to attain a reasonable level of speech perception, but a significant portion obtains poor levels of speech perception or, at the worst, only awareness of environmental sounds [2] – [4].

The purpose of this project is to determine the minimum system requirements necessary for a CI artifact-removal EEG system. We will design a low-cost amplifier and combine it with a computer sound card (which is an AD converter) to make a low-cost EEG system, program software to control the experiments and to display and analyze the data, and test the system's ability to remove CI artifact. This would advance our understanding of why the expensive system works and what components make that possible, as well as make the technique more widely accessible. After our low-cost (<\$50) system can be implemented, CI users will be able to measure their neural responses at home and send the data to the audiologist rather than having to go to the audiologist themselves. Currently CI users need to visit the audiologist every few months to check whether the CI provides the correct amount of electrical stimulation; performing this test at home could save time for both audiologists and CI users and significantly reduce medical expenses.

## 2. Design and Experiments

### 2.1 Cochlear implant

A cochlear implant is an electronic hearing device surgically implanted into a patient's cochlea, designed to produce hearing sensations in a person with severe deafness by electrically stimulating the auditory nerve [5]. The implant consists of two main components (figure 1): (1) the external microphone, sound processor, and transmitter; and (2) the implanted receiver and electrodes. The internal system receives signals from the external system and sends electrical currents to activate the nerve, which then sends signals to the brain. The brain learns to recognize and interpret these signals and the person experiences perception of sound.

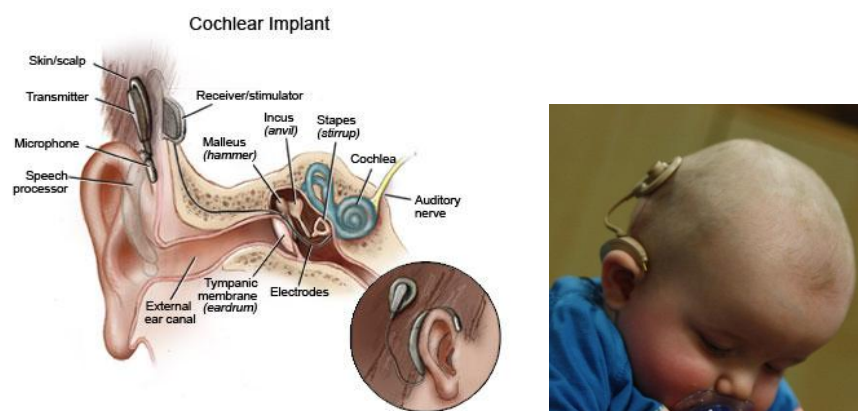

Figure 1: Cochlear implant configuration and how it works [5].

## 2.2 Cochlear implant fitting and remote monitoring

Because the extent and type of hair cell damage, the electrical signal patterns, and the sensitivity of the hearing nerve are different for each person, a specialist must fine-tune the sound and speech processor for each patient. The audiologist sends different currents through each electrode and asks the patient the minimum threshold and maximum comfort volumes; depending on the brand, there can be up to 22 electrodes in the CI. By measuring the lowest and highest currents for each electrode, the audiologist sets the minimum and maximum levels of neural stimulation for that patient. . The audiologist must also select the best type of speech processing strategy for that user and adjust a complex set of parameters which include the number of electrical pulses per second sent to each electrode, the duration of each pulse and the acoustic frequency bandwidth assigned to each electrode. Getting these settings correct is key to the users being able to achieve a high level of speech perception.

This project will determine the minimum system requirements of the EEG system in order to measure CEPs and remove electrical artifact for CI users to make the system more reliable and each component easier to optimize. This project will also develop a low-cost EEG system which allows CI users to measure their neural responses at home. They can simply send the files to their audiologist (figure 2), and will not have to come into the clinic unless something goes wrong.

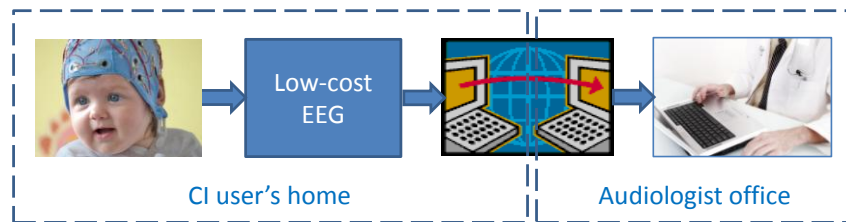

Figure 2: Potential application of the low-cost EEG system. With this system, CI users could measure their neural responses at home and send the results to audiologist. Doing this at home could save time for both the audiologist and the CI user and significantly reduce medical expenses. The patient would only have to go to the clinic if the audiologist notices something unusual about the neural responses.

### 2.3 Designing the low-cost EEG system for cochlear implant evaluation

The low-cost EEG system for CI application requires CI artifact cancellation in addition to the standard EEG components. Figure 3 is a diagram of the necessary components for an EEG system for CI user assessment. The CI stimulus signal is produced by the signal generator and delivered to the CI which stimulates the patient's brain to invoke a sensation of "sound". The CEP signal induced in the brain by this "sound" is then picked up by the electrodes, amplified by the amplifier circuit, translated back to a digital signal by the AD converter, and finally sent to the laptop computer, where the data is collected and analyzed. The laptop computer is the central control unit which runs a MATLAB program to generate the stimulus signal, collect and process the EEG response, and display the CEP signal on a graph. The AD converter available in a computer sound card was used to perform AD conversions while a special amplifier circuit was designed for CEP signal amplification.



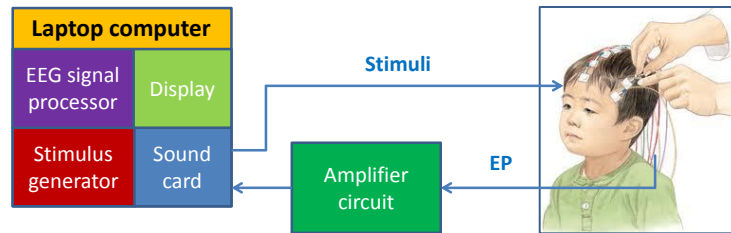

Figure 3: Diagram of the low-cost portable EEG system specialized for brain wave acquisition in cochlear implant users. The system includes a laptop computer as the center control unit, electrodes to collect CEP signal, amplifier circuit for signal amplification and filtering, and necessary connecting wires.

## 2.4 Amplifier circuit

The amplifier circuit is the most important and expensive component of the EEG system. The Stanford Research Systems Model SR560 Low-Noise Preamplifier is a commercial amplifier that has been proven to be effective in EEG systems. In designing and testing my amplifier, we used the SR560 as a baseline to judge the performance of the design. Two identical experiments were conducted during each test – one using the SR560 and the other using my amplifier. The results were compared and the difference was used to evaluate and improve the performance of my amplifier circuit. Figure 4 (a) shows the SR560 diagram that includes three amplifier stages and two filter stages.

The design of my amplifier circuit started with a single-stage circuit consisting of just one amplifier (Amp1). After testing the circuit, each additional component was added individually to the circuit in order to isolate the effect of each component; this helped identify the minimum system requirements for a functional EEG system offering reasonable results in CI subjects. Figure 4 (b) shows the diagram of the amplifier circuit for the low-cost EEG system. Initially, only one amplifier (Amp1) was used to amplify the CEP signal; after comparing the data acquired through Amp1 with that through the SR560 and noticing significantly greater high-frequency electrical artifact, a low-pass filter with a cutoff frequency 100 Hz was built and connected to the circuit. This allowed common neural responses (2 Hz – 35 Hz) to pass through while blocking the CI artifact (>1,000 Hz). The next step would be to add another amplifier (Amp2) to determine whether 2-stage amplification is necessary.

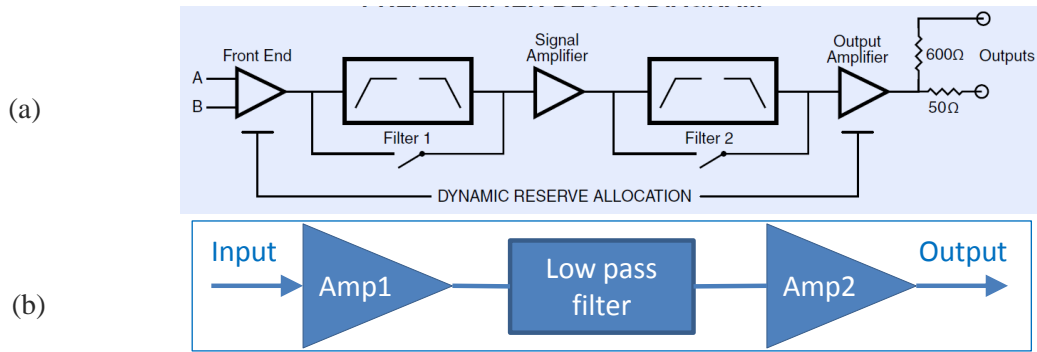

Figure 4: Diagram of SR560 low-noise preamplifier (a) [6] and my amplifier circuit (b). My amplifier circuit was tested in 3 phases. In phase 1, a single-stage amplifier was used. In phase 2, a low-pass filter was added that allows the CEP signal pass but blocks the CI artifact. In phase 3, the second stage amplifier would be added and evaluated to see how much a second stage improves the signal quality. Both phase 1 and 2 have been implemented and tested.

## 2.5 Sound card AD converter

The AD converter is the second most expensive component in the EEG system. As a low-cost alternative to an expensive commercial AD converter, we used the AD converter found in PC sound cards to perform the CEP signal conversion. We systematically tested the frequency response of the sound card in the HP Pavilion dv6 laptop computer and verified that it can handle low frequency neural responses. The National Instruments USB-6221 Data Acquisition (DAQ) device was used as the baseline AD converter for the experiments.

## 2.6 Software programming

Programs written in MATLAB were used for stimulus signal generation, real-time CEP signal display, and EEG data recording and processing (Figure 5). Three parameters – frequency, amplitude, and duration – were input into the MATLAB program and stimulus signals were generated accordingly. The stimulus signal was sent to the subject's CI, and the responding CEP signals were then detected by electrodes, amplified by the amplifier circuit, and converted to digital signal through the AD converter. The CEP signals were then recorded, processed, and displayed with MATLAB.

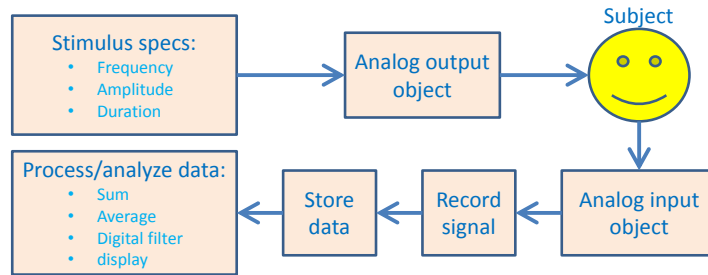

Figure 5: Software diagram for signal generation and data processing using MATLAB.

After the two most basic functions of the EEG system software were designed, the next step was to design the graphical user interface (GUI). The GUI included buttons for calling the play and record functions, boxes to indicate the subject and the date of the session that updates the title of the recorded file, options for the play and record functions, and a real-time oscilloscope display that puts a signal inputted into the laptop sound card onto a graph. Figure 6 shows the program GUI used in this experiment.

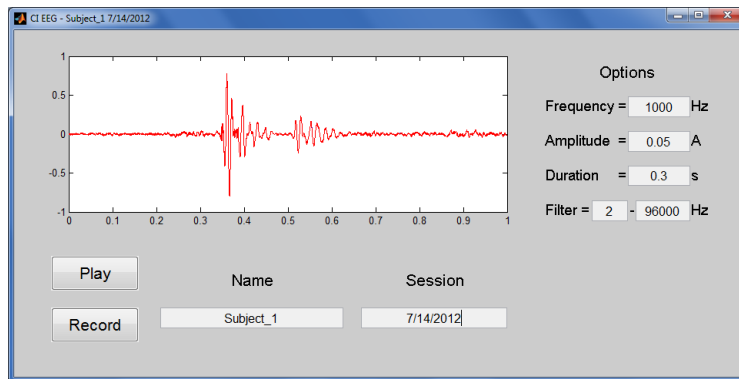

Figure 6: The graphical user interface used in the experiments includes buttons, boxes, options, and a real-time oscilloscope. The oscilloscope will display the signals that the EEG system detects.

## 2.7 Human subject preparation and testing

After the amplifier circuit was assembled and debugged, we moved on to human subject testing. Alcohol and abrasive gel were first used to clean the subject's skin and to remove any dead skin cells, after which the electrodes were placed on the subject, using electrode cream to achieve optimal contact. The positive electrode was attached at CZ (the top of the head), negative on the mastoid opposite the stimulus ear, and ground on the corresponding collarbone. After securing all 3 electrodes, the electrode

impedances were measured. If any impedance was measured to be above 5 k $\Omega$ , the electrodes were re-adjusted to lower their impedances. When all impedances were less than 5 k $\Omega$  and within approximately 0.5 k $\Omega$  of each other, the electrodes were connected to the amplifier circuit and the experiment was initiated.

### 3. Results and Analysis

#### 3.1 Sound card AD converter evaluation

Computer sound cards are designed to produce and record sounds audible to the human ear, whose frequencies range from 20 Hz to 20 kHz. CEP signals are typically between 2 Hz and 35 Hz; in order to verify whether the sound card AD converter could handle such low frequencies in the neural response, we systematically measured the sound card's frequency response, and the results are shown in Figure 7. The sound card found in the model HP Pavilion dv6 laptop computer has a relatively flat frequency response between 20 Hz and 10 kHz, which covers most of the audible frequency range. However, for <10 Hz frequencies, the sound card performance is not as good. Fortunately, as our experiments confirmed, the sound card can still process the CEP signals despite signal attenuation. In future study, this attenuation should be considered and compensated.

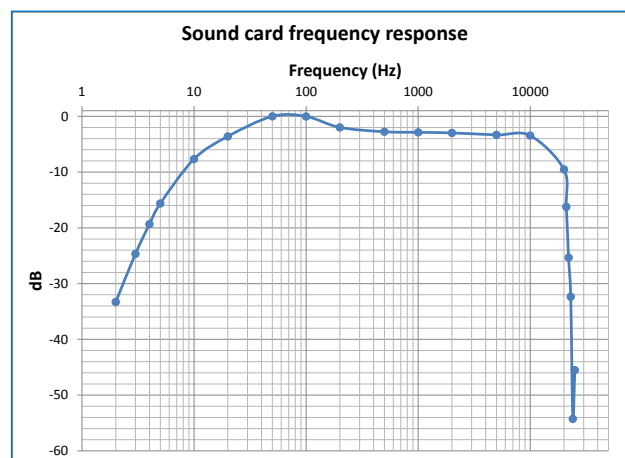

Figure 7: Frequency response of sound card in HP Pavilion dv6 laptop computer; measurements were conducted in frequency range of 2 Hz – 25 kHz.

### 3.2 Single-stage amplifier circuit evaluation

Due to its resistance to DC offset, low noise, high gain (up to 10,000), and low cost (\$5 – \$10), the AD620 instrumentation amplifier was selected for my amplifier circuit. Figure 8 shows a diagram and a picture of my amplifier circuit designed for the low-cost EEG system. In order to make the circuit more adaptive during the experiment, a 0 – 1 k $\Omega$  variable resistor was used in series with a 50  $\Omega$  resistor to allow the gain to be changed between 50 and 1,000. To reduce the noise, a 9 V battery was used to power the circuit to avoid any 60 Hz AC interference. This was also safer for measurements in humans since there is no direct connection to the mains power. Figure 9 shows the output waveform and frequency response when the gain was set to 1,000. A sinusoidal signal with 1 kHz frequency and 1 mV amplitude was generated from the Audio Precision Analog Generator and input into the circuit; the output waveform from the circuit was captured by a Tektronics digital oscilloscope and displayed in Figure 9 (a). Here, the peak-to-peak amplitude is 1.06 V. Figure 9 (b) shows that the amplifier circuit has a flat response in the frequency range of 20 Hz – 20 kHz.

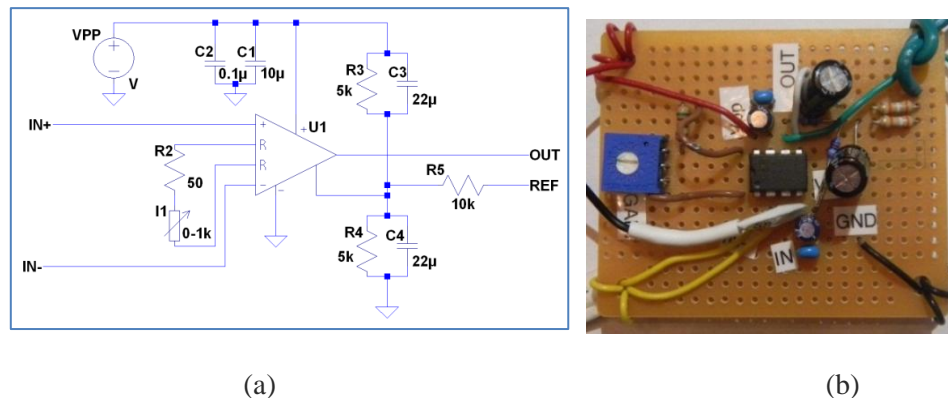
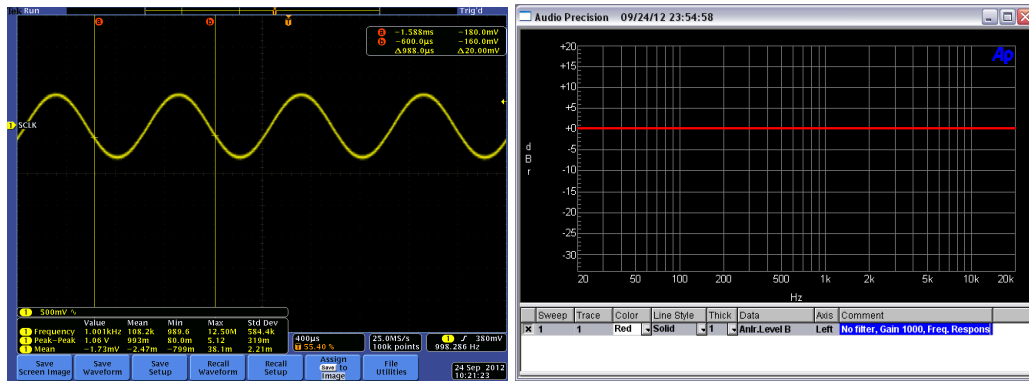

Figure 8: Diagram (a) and picture (b) of my amplifier circuit. This is a single-stage amplifier based on AD620 instrumentation amplifier. A 9 V battery was used to power the circuit to avoid any 60 Hz AC interference. Besides reducing noise, using a battery was also safer for measurements in humans since there is no direct connection to the mains power. A 0 – 1 k $\Omega$  variable resistor was used in series with a 50  $\Omega$  resistor to allow a variable gain between 50 and 1,000, so that the circuit is more adaptive during the experiment.



(a) (b)  
 Figure 9: The output waveform (a) and frequency response (b) of the amplifier circuit (gain was 1,000).

### 3.3 Electrocardiogram measurement

Electrical potentials produced by heartbeat are around 2 to 3 mV, much larger than the brain's neural responses, so it is an easy way to verify that the EEG system has been wired correctly and is functioning properly. The electrocardiogram (ECG) setup is prepared by placing an electrode on each side of a person's chest, amplifying the signal by using the EEG system (set to a smaller gain), and inputting the signal into the computer through the sound card for data analysis. Figure 10 shows the acquired ECG signal showing the typical QRS complex. This confirms that the EEG system is working properly and can acquire bio-signals.

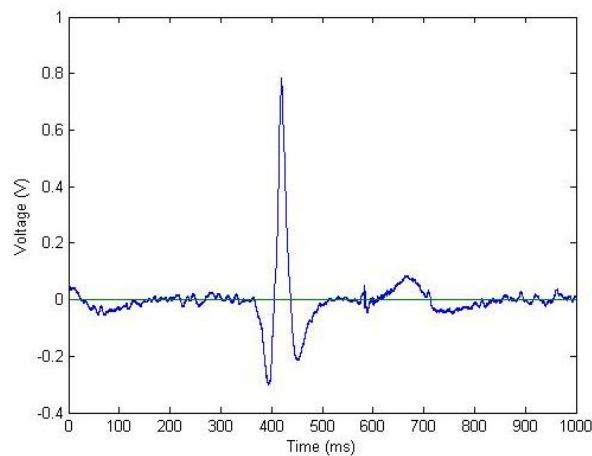

Figure 10: ECG signal showing the typical QRS complex was detected by the low-cost EEG system.

### 3.4 Neural responses measurement in normal-hearing subjects

Before the low-cost EEG system was tested on CI subjects, it was first tested on normal hearing subjects as a preliminary experiment. Because there is no CI electrical artifact in normal hearing people, it is much easier to acquire accurate results. In each experiment, two identical tests were performed. The SR560 amplifier was used in one test to acquire baseline data and my amplifier was used in the other test; the results from the two amplifiers were then compared.

The subject sat in a soundproof booth with the electrodes attached on his head. A pure tone was generated by the laptop; the tone lasted for 300 ms and repeated every second. A trigger signal was generated simultaneous to the beginning of the 300 ms tone and sent back into the computer as a timer object for data analysis. The tone was sent to an earphone in one of the subject's ears. When the subject heard the tone, a CEP was induced in the subject's brain, which was then detected by the electrodes as a voltage. This voltage was amplified by the SR560 amplifier in one experiment and by my amplifier in the other, converted to a digital signal by the sound card, and the entire CEP signal was recorded and displayed by the computer in real-time. The tone was repeated 200 times for each experiment and for each trigger timer object, the computer took a segment of the data 100 ms before to 500 ms after the trigger and used this for the analysis. This CEP signal segment was averaged with the previous segments. Since the N100 response is very small and buried in the background noise, it cannot be seen in each individual segment; however, after averaging the signal, the random noise should cancel itself out and the signal appears. After averaging 200 times, a clear CEP signal can be seen.

Figure 11 compares the CEP signals processed by the SR560 and by my amplifier in two experiments. The SR560 and my amplifier had somewhat different gains; for easier comparison, both CEP signals were normalized. In the waveforms, a very clear N100 response is visible for both amplifiers in both experiments. The CEP signal processed by my amplifier has slightly more trigger interference than that processed by the SR560, but the N100s are nearly identical in terms of timing and shape. This experiment demonstrated that a single-stage amplifier is able to detect CEP signals in normal hearing people.

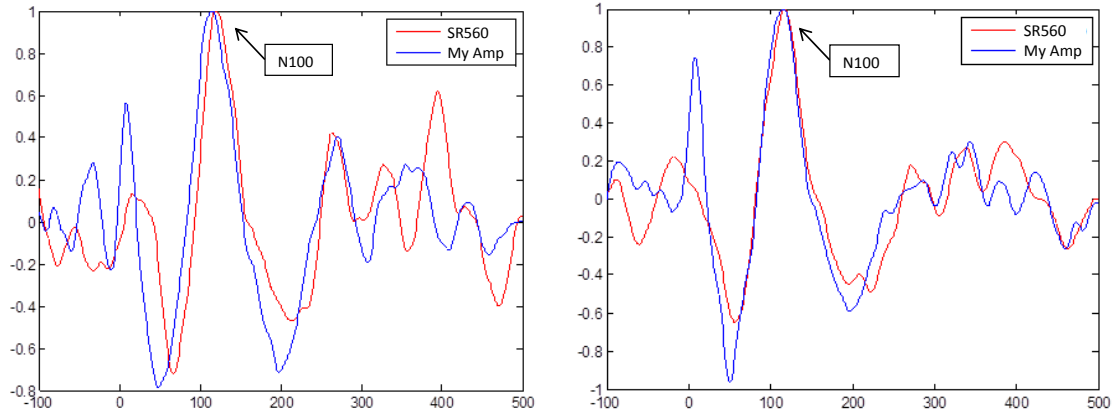

(a) CEP signal in experiment #1

(b) CEP signal in experiment #2

Figure 11: Comparison between my amplifier recorded (blue line) and SR560 amplifier recorded (red line) cortical evoked potentials. For ease of comparison both signals have been normalized. Note the similar timing of the large N100 around 100 ms. The signal is reversed from the conventional N100 depression; this is due to the reversed attachment of the electrodes.

### 3.5 Neural responses measurement in CI subjects

After confirming that the single-stage amplifier is able to process CEP signals in normal hearing people, we then tested it on CI users to explore how the CI artifact affects CEP measurement. The experiment procedure was very similar to that for normal hearing subjects. A CI subject sat in a soundproof booth with the electrodes attached to his or her head. The same pure tone was generated with 300 ms on and 700 ms off for 200 repetitions. One key difference was that, instead of sending the tone to an earphone in the normal hearing subject, the tone was sent directly to the sound processor of the CI. The processor then translated the tone into a stimulus signal that was then sent to CI electrodes inside the cochlea to generate the sensation of “sound” in the CI subject’s brain. This induces a CEP signal in the subject's brain, which was recorded and processed by the computer. This procedure was performed for three CI subjects.

Figure 12 shows the CEP signal comparison between signals processed by the SR560 and by my amplifier for CI subject #1 and CI subject #2. The CEP signals from these CI subjects have significantly more noise than those from normal hearing subjects. However, the N100 component is still visible for both amplifiers and for both subjects. Note that CI subject #1 has an early N100 at around 70 ms,



different from the normal N100 which usually occurs between 80 ms and 120 ms. The N100 neural response of the brain is not fully developed until around age 13 in normal hearing children. CI subject #1 was deaf in both ears from birth and his N100 developed differently, which is the reason for the subject's early N100 and the unusual shape of the waveform. CI subject #2 experienced hearing loss as an adult; therefore he has a more normal N100. The CEP signals processed by my amplifier have more high frequency noise than those processed by SR560, showing the limits of a single-stage amplifier circuit. Nevertheless the N100 times and shapes are still very similar.

Figure 13 shows the comparison for CEP signals processed by the SR560, by my amplifier, and by the NeuroScan SynAmps<sup>2</sup> system for CI subject #3. The NeuroScan SynAmps<sup>2</sup> is a state-of-the-art commercial EEG data acquisition and analysis system. This system features integrated platforms designed to allow seamless recording and analysis of EEG data across a variety of domains. It has a clearer, less noisy signal than both the SR560 and my amplifier; however, all three systems show similarly-timed N100s. The experiments demonstrate that the single-stage amplifier is also able to detect CEP signals in CI users. However, the high frequency noise contaminates the signal.

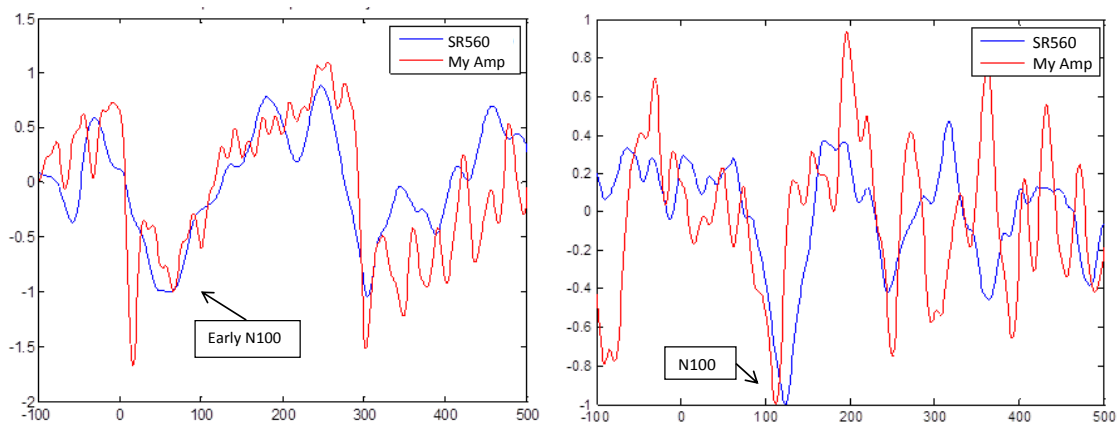

(a) CEP signal induced in CI subject #1  
(deaf from birth)

(b) CEP signal induced in CI subject #2  
(deaf as adult)

Figure 12: Comparison between my amplifier recorded and SR560 amplifier recorded CEP signals for CI subjects #1 (a) and #2 (b). The blue line shows the CEP recorded using my amplifier and the red line using the SR560 amplifier. For ease of comparison both signals have been normalized. Note the similar timing and shape of the N100 peak.

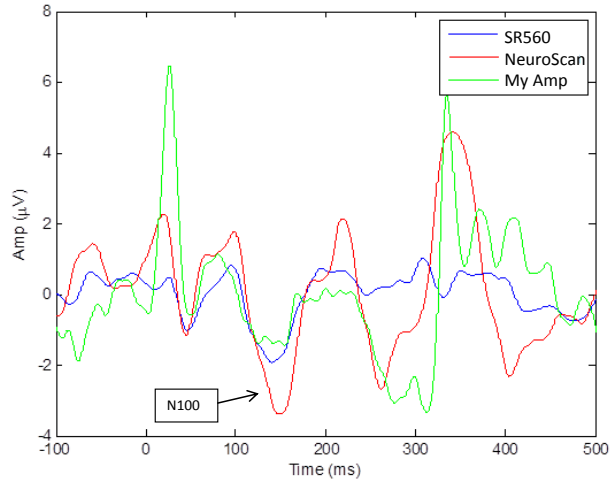

Figure 13: CEP signal induced in CI subject #3 (experienced hearing loss as an adult). Comparison among my amplifier recorded (green line), SR560 amplifier recorded (blue line), and NeuroScan system recorded (red line) CEP signals. Note the similar timing and shape of the N100 peak.

### 3.6 Low-pass filter design and evaluation

Above experiments showed the single-stage amplifier circuit is able to detect the N100 signal, but the high frequency noise (CI artifact) contaminates the CEP signal. A low-pass filter is necessary to eliminate the CI artifact. Figure 14 shows a diagram and a picture of the low-pass filter circuit that was designed using the N5532 differential amplifier. Since brain wave signals are generally in the frequency bandwidth 2 Hz – 35 Hz, this low-pass filter was designed to have a cutoff frequency of 100 Hz. Figure 15 shows the filter's frequency response. The results show that there is >20 dB attenuation for noise with >1 kHz frequency, so most of the high-frequency CI artifact will be blocked.

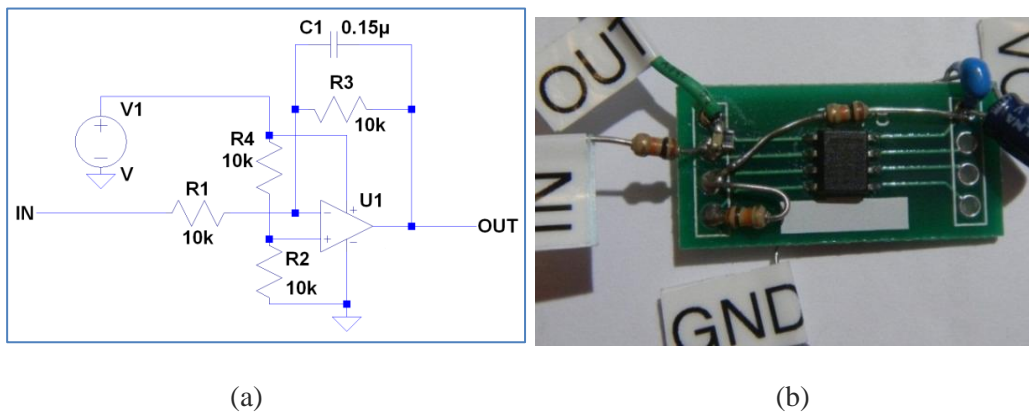

Figure 14: Diagram (a) and picture (b) of the low-pass filter with a cutoff frequency of 100 Hz.

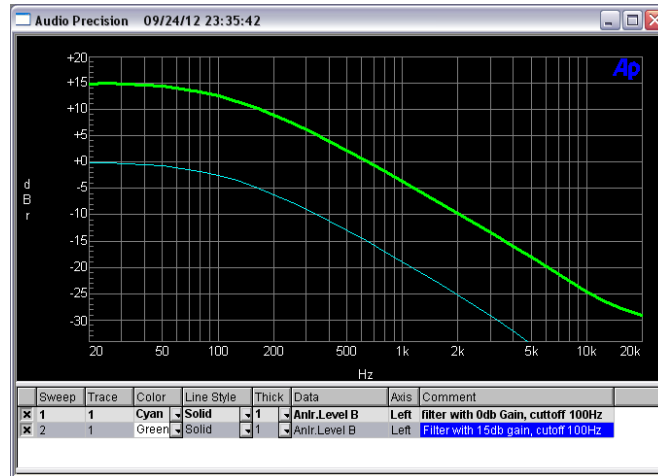

Figure 15: Frequency response of the low-pass filter when the gain was set to 1 (blue line) and when it was set to 6 (green line).

### 3.7 Neural responses measurement in CI subjects by amplifier with low-pass filter

The low-pass filter was integrated into the single-stage amplifier by connecting the filter input to the amplifier output. The CEP signal detected by electrodes was amplified first and then sent to the low-pass filter and the sound card. The same experiment as mentioned in Section 3.5 was conducted on CI subject #4. Figure 16 shows the CEP signal comparison between signals processed by the SR560 and by my amplifier with the low-pass filter. The CEP signals processed by the two amplifiers are extremely similar in both shape and noise level, indicating that the low-pass filter significantly reduced the CI artifact. This experiment indicates that the minimum system requirements for an EEG system to be able to effectively remove CI artifact should include a single-stage amplifier and a low-pass filter. This low-cost EEG system can be able to replace the expensive SR560 system for most CI fitting and evaluation and with additional optimization measures should be able to substitute professional EEG systems in CI research. The additional studies should focus on optimizing each of the two basic components.

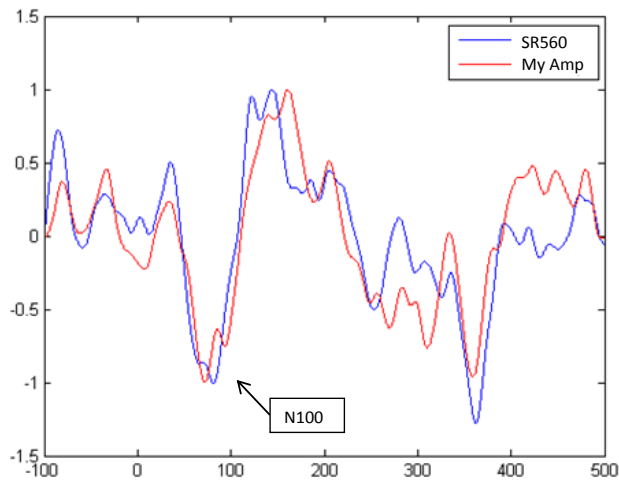

Figure 16: CEP signal induced in CI subject #4. Comparison among my amplifier recorded (red line) and SR560 amplifier recorded (blue line) CEP signals. The two CEP signals are very similar, having similar noise level, which indicates the low-pass filter significantly reduced the CI artifact and improved the performance of the single-stage amplifier.

#### 4. Discussion and Future Work

Although the low-cost EEG system has demonstrated that a circuit consisting of a single-stage amplifier and a low-pass filter is able to produce reasonably accurate CEP signals, there are certainly many aspects that can still be improved. Additional studies can be done to identify what other components are critical for CI artifact handling or removal. These questions should be answered: (1) how many amplification stages and filters are optimal; (2) what characteristics the amplifier and filter should have; (3) how the circuit configuration affects the CI artifact removal and CEP signal detection. Future experiments have also been planned to test different amplifier chips to see if they handle the CI artifact similarly and which one offers the best results.

- Use non-contact dry electrodes for a faster test preparation. This would reduce the time required to test a subject by removing the need to scrub the skin and attach the electrodes.
- Integrate the signal conditioning circuit into the CI itself. The CI currently contains a small amplifier that can record signals from the auditory nerve, but it has problems handling its own

artifact during nerve stimulation. If we perfect my amplifier's design we could incorporate it into future CIs and record artifact-free data from the auditory nerve and the auditory cortex, ultimately making a closed-loop CI.

- Develop methods for remote storage or transmission of EEG data to audiologist.
- Formulate algorithms to automatically detect if neural responses are normal or if the audiologist should be alerted to a problem.
- Design better circuits to remove onset artifacts and DC offset.

## **5. Conclusion**

This project demonstrated that a specially-designed, single-stage amplifier in addition to a low-pass filter and the AD converter in a normal laptop sound card is able to detect the CEP signals from CI users with quality comparable to the high quality, expensive SR560 amplifier system. This systematic study of each component of the EEG system found the minimum system requirements for a functional EEG system for CI applications. This EEG system can be introduced to an in-home setting, as the simpler design allows it to be low-cost without compromising performance. Recent research has shown that it is possible to objectively assess CI performance by measuring neural responses by using an EEG system; however, the expense of current EEG systems prevents audiologists and CI users from exploring this method. Our low-cost EEG system will overcome this obstacle and make CI evaluations much easier.

The cumulative hardware of my EEG system consists of electrodes, an amplifier circuit with a low-pass filter, and a computer. Assuming the patient already owns a computer whose sound card is not obsolete, the low-cost EEG system will total <\$50. By contrast, the SR560 amplifier with the NI USB-6221 DAQ card costs around \$5,000 and the NeuroScan SynAmps<sup>2</sup> system costs around \$20,000.

This low-cost EEG system has the potential to radically improve conditions for CI patients in both treatment and follow-up by making patient care easier and more accessible to CI users and audiologists. Also, an objective assessment of CI performance that does not require asking the patients is

a much better way to evaluate CI performance, especially for young children who cannot give reliable verbal feedback. This system allows CI users to measure their neural responses at home independently and simply send the recorded files to the audiologist. In addition to reducing medical expenses, the in-home CI assessment system will assure parents of young CI users that the CI is functioning properly and that the child's auditory system is developing normally.

## **References:**

- [1] Pleis JR, Lethbridge-Cejku M. Summary health statistics for U.S. adults: National Health Interview Survey, 2006. *Vital Health Stat 10 2007*;(235):1-153.
- [2] R. V. Shannon, F. G. Zeng, V. Kamath, J. Wygonski, and M. Ekelid, "Speech recognition with primarily temporal cues," *Science*, vol. 270, pp. 303–4, Oct. 1995.
- [3] F.-G. Zeng, S. Rebscher, W. V. Harrison, X. Sun, and H. Feng, "Cochlear implants: System design, integration and evaluation," *IEEE Rev. Biomed. Eng.*, vol. 1, pp. 115–142, Jan. 2008.
- [4] B. S. Wilson, C. C. Finley, D. T. Lawson, R. D. Wolford, D. K. Eddington, and W. M. Rabinowitz, "Better speech recognition with cochlear implants," *Nature*, vol. 352, no. 6332, pp. 236–8, Jul. 1991.
- [5] Kids health, <http://kidshealth.org/parent/general/eyes/cochlear.html>
- [6] Stanford Research Systems Model SR560 Low-Noise Preamplifier data sheet, <http://www.thinksrs.com/downloads/PDFs/Catalog/SR560c.pdf>